

STERILMATIC

ANALOG ELECTRIC STERILIZER

INSTALLATION - OPERATION - MAINTENANCE



MODELS

- STM-E
- STM-EL
- STM-EX
- STM-ELX



MARKET FORGE
INDUSTRIES INC.



44 Lakeside Avenue, Burlington, Vermont 05401 USA

Telephone: (802) 658-6600 Fax: (802) 864-0183

www.mfi.com

PN 14-0411 Rev C (12/15)

Your Service Agency's Address:

Model

Serial number

Sterilizer installed by

Installation checked by

IMPORTANT

WARNING: Improper installation, adjustment, alternation, service or maintenance can cause property damage, injury or death. Read the installation, operation and maintenance instructions thoroughly before installing or servicing this equipment.

FOR YOUR SAFETY

Do not store or use gasoline or other flammable vapors or liquids in the vicinity of this or any other appliance.

The information contained in this manual is important for the proper installation, use, and maintenance of this sterilizer. Adherence to these procedures and instructions will result in satisfactory baking results and long, trouble free service. Please read this manual carefully and retain it for future reference.

ERRORS: Descriptive, typographic or pictorial errors are subject to correction. Specifications are subject to change without notice.

TABLE OF CONTENTS

INSTALLATION

Introduction.....	2
Service Connections	3
Installation Instructions	4
Optional Cold Water Condenser.....	5
Pan Supports and Baffles.....	6
Optional Stands.....	8
Optional Recording Thermometer.....	9

OPERATION

Operating Instructions	10
Minimum Sterilization Times	11

MAINTENANCE

Cleaning	12
Warranty	13

Introduction

OPERATING ENVIRONMENTAL CONDITIONS

This unit is designed for commercial use and to be safe at least under the following conditions:

- For indoor use only.
- For use at altitudes up to 6500 ft (2000 m)
- For use at temperatures from 41°F (5°C) to 104°F (40°C).
- Maximum relative humidity 80% for temperatures up to 88°F (31°C) decreasing linearly to 50% relative humidity at 104°F (40°C).
- Main supply voltage fluctuations not to exceed \pm 10% of nominal voltage.
- Transient overvoltages according to Installation Categories II (in accordance with IEC 664).
- Pollution Degree 2 (in accordance with IEC 664).

INTENDED USE - DUTY CYCLE

This unit is intended to be operated intermittently. After a pre-heat cycle, the longest period of use is 60 minutes. The timer allows a maximum of 60 minutes. After each use the unit should be opened for removal and reloading of product. The water level should be checked after each use and refilled when necessary.

SERVICE & TECHNICAL INFORMATION CONTACT



WARNING

This unit should be serviced by qualified service personnel only.

Your Sterilmatic Sterilizer has been developed to answer the need for a compact, automatic, low-cost steam pressure sterilizer. The following instructions cover installation. Should service be required, it is readily available by contacting our authorized service agency located nearest to you. The name of your local service company can be obtained on our website, www.mfii.com.

WATER CONDITIONS

When sterilizing culture mediums that generate sulfide gas or chlorine gas, the inside of the chamber must be cleaned and rinsed thoroughly without fail.

Market Forge from time to time is asked the question about using distilled or deionized water for use with our Sterilizer models STM-E and STM-EL. We are always asked why these water choices are not allowed for use with our units and what would be recommended. To address this situation, we have compiled the following as a means of satisfying these questions:

1. We have found that the use of distilled or deionized water will aggressively attack the pure coat of Aluminum Alclad, which protects the bottom surface from oxidizing and then eventually pitting (reference: Operating and Maintenance Instructions).
2. In addition pitting can also be caused by several other external environmental factors. Few examples are as follows. These conditions have been highlighted in our documentation.
 - Grains of hardness in the water supply should be as follows (.25 to 2).
 - A pH imbalance in the water supply can greatly affect the life to the aluminum cylinder. The pH range that would be recommended is between 7.0-8.5.
 - The lack of a positive electrical ground can cause an electrolytic reaction that will accelerate pitting.
 - Another contribution to accelerate pitting is the type of cleaning solutions used or the abrasive scrubbing pads. If a low pH is present with the detergents being used or an abrasive pad, the protective Alclad coating will be removed during the cleaning process.
 - Spillage of media being sterilized can also contribute to the accelerated pitting if it is corrosive.
 - CHLORINE LEVEL \leq 1 PPM.



IMPORTANT

Market Forge will not be responsible for damage resulting from the use of hard or corrosive water, from failure to drain the unit daily, or from inadequate cleaning procedures.

ELECTRICAL SPECIFICATIONS

Domestic Models	kW	Hz	1 Phase		3 Phase	
			208V	240V	208V	240V
STM-E	9.3	60	45A	-	26A	-
STM-EL	12.4	60	-	52A	-	30A

Export Models	kW	Hz	1 Phase		3 Phase	
			220V	240V	220/380V	240/415V
STM-EX	10.4	50	48A	-	16A	-
STM-ELX	12.4	50	-	52A	-	18A

Unit must be grounded. Main supply voltage fluctuations are not to exceed $\pm 10\%$ nominal supply voltage.

WATER SUPPLY

Good quality water feed is the responsibility of the owner. Water quality must be within the following general guidelines.

TDS: 40-125 ppm Hardness: 35-100 ppm Chlorine: <0.2 ppm
 Silica: <13 ppm Chlorides: <25 ppm
 Chloramine: <0.2 ppm pH: 7.0 - 8.5

The best defense against poor water quality is a water treatment system designed to meet your water quality conditions.

Appliance to be installed with backflow protection according to federal, state or local codes.

SERVICE CONNECTIONS

A	Drain - 1/2" (13mm) N.P.T. of 3/8" (10mm) OD copper (see note 1)
B	Steam Exhaust Connection - 5/8" (16mm) (see note 2)
C	Electrical Connection - (*see electrical specifications table)
D	Power Supply

NOTES:

1. An air break must be provided if a unit drain line is run.
2. Vent exhaust to atmosphere. B1 is actual connection, but must exit casing at B.

IMPORTANT: Exhaust line must be vented to the outside to eliminate the exhaust steam and the accompanying noise from entering the room. Use 1/2" (13mm) copper tubing or suitable alternate. The overall height and length of the line should not rise more than 4' (1.2 meters) above the unit and exceed 15' (4.5 meters) with a minimum of bends. The line should slope downward after leaving the sterilizer in order to ensure condensate drainage.

IMPORTANT: Failure to comply with this outline will affect the sterilization process.

When an exhaust condenser is supplied; the following services must be provided: 1/2" (13mm) cold water: 1" (25mm) waste: 115V electrical line.

DIMENSIONS ARE IN INCHES [MM]

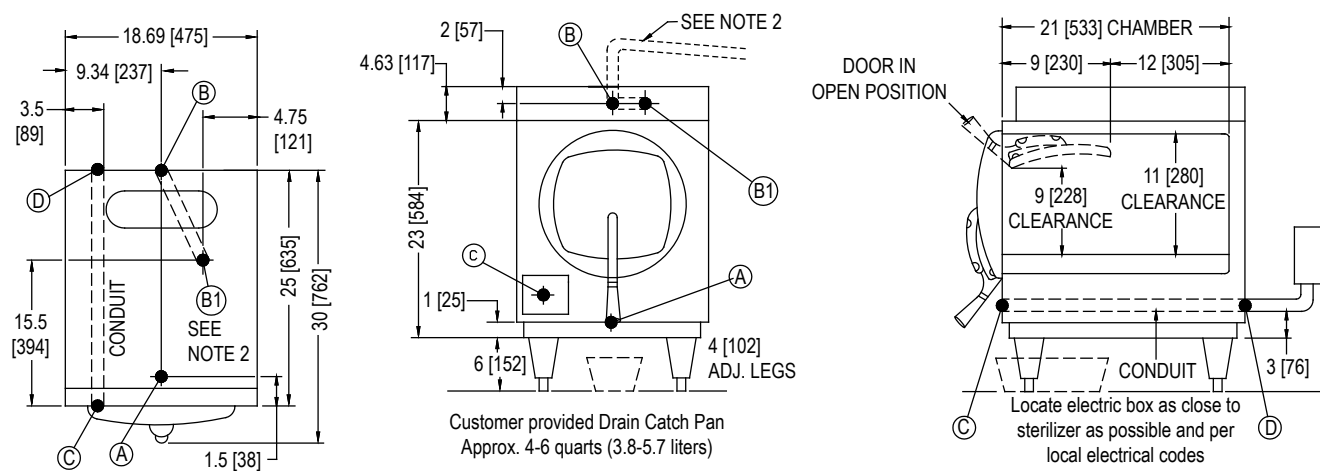

Figure 1

Installation Instructions

INSTALLATION

Set sterilizer on counter, using the 6" (152mm) legs provided or assemble the optional stainless steel stand with under-shelf.

If your Sterilmatic includes a water-cooled exhaust condenser, we recommend the use of the Sterilmatic stand, part number 95-6060.

First, level unit in place, then adjust rear legs to pitch the unit forward 1/4" (6mm) to insure positive drainage of the cylinder.

ELECTRICAL

Connect to proper electrical supply box and disconnect switch as shown on one of the following schematic diagrams - 208 or 240 volts, single or three phase. Connection is made from the rear of the unit, through the conduit to the terminal box located at the front of the unit.

Electric supply connection for STM-E & STM-EL

Connect to proper electrical supply as indicated on nameplate on top of unit. The power supply cord is brought in from the rear of the unit, through the conduit and the connection is made at the terminal box located at the front of the unit.

Electric supply connection for STM-EX & STM-ELX (export models)

Connect to proper electrical supply as indicated on nameplate on top of unit. Connection is made from the rear of the unit, through the conduit to the terminal box located at the front of the unit. All control circuits are 220 volts.

In order to accomplish this, a current-carrying grounded neutral must be provided.

Thus, a three phase system must be 4-wires. Most electrical codes require, and we recommend, that a separate switch be located within sight of the sterilizer.

OUTSIDE VENTING

Connect 1/2" (13mm) nominal tubing exhaust to outside vent connection located on top of unit, within the control housing.

IMPORTANT: Exhaust line must be vented to the outside to eliminate the exhausted steam and the accompanying noise from entering the room.

Use 1/2" (13mm) copper tubing or suitable alternate. The overall height and length of the line should not rise more than 4 feet (1.2 meters) above the unit and exceed 15 feet (4.5 meters) with a minimum of bends. The line should slope downward after leaving the sterilizer in order to insure condensate drainage.

WATER-COOLED EXHAUST CONDENSER

If outside venting is not possible, an optional water-cooled condenser is available for connection to an open drain. If required order part no. 95-0436 kit.

RECORDING THERMOMETER

If a recording thermometer is provided, refer to installation guide provided with recorder.

TRAY SUPPORTS

Install side tray supports. Tray supports are attached by means of key-hole clearance slots which are slipped over studs located on the sides of the Sterilmatic chamber.

BAFFLE INSTALLATION

To insure maximum drying of packs, a baffle is supplied with your Sterilmatic. Place perforated splash baffle in bottom of the sterilizing chamber. Install small baffle with no perforation at the rear of the upper tray support channel.

NOTE: The perforated baffle is not to be used as a shelf to place media or other items. It is intended to eliminate splashing.

OPERATION CHECK

To check for proper operation of unit:

3. Close drain valve by turning handle clockwise.



WARNING

DO NOT OPEN DRAIN VALVE WHILE UNIT IS OPERATING. PREMATURE OPENING MAY RESULT IN SCALDING OF OPERATOR.

4. Fill chamber with 4 to 6 quarts (3.7 to 5.6 liters) of ordinary tap water. DO NOT USE DISTILLED OR DE-IONIZED WATER.
5. Close chamber door.
6. Set exhaust selector to INSTRUMENTS AND PACKS (fast exhaust) or LIQUIDS (slow exhaust).
7. Set timer to 15 minutes. Cycle will go to completion automatically.

NOTE: Cycle timer will not start until sterilizing temperature is obtained.

Optional Cold Water Condenser

Item	Part No.	Description	Qty
1	95-2119	Steam condensing unit	1
2	95-2219	Thermostat Box Assy.	1
3	95-0086	Exhaust line	1
5	15-7057	Copper tubing 3/8 OD	22.25"
6	10-1775	Rd. Hd. Mach. Screw, 1/4-20	2
7	10-2500	Lockwasher, 1/4	2
8	10-2308	Hex Nut, 1/4-20	2
9	10-1812	Rd. Hd. Mach. Screw, 10-32	2
10	10-2505	Lockwasher, 10	2
11	10-2340	Hex Nut, 10-32	2
12	95-4009	Front Template (7" Lg)	1
13	95-4010	Back Template (11" Lg)	1

SERVICE CONNECTIONS REQUIRED	
A	1/2" IPS Cold Water Connection
B	1" IPS Drain Connection (See Note 3)
C	115V Elec. Connection 7/8 Ø knockout (cond. unit)
D	Electrical Connection

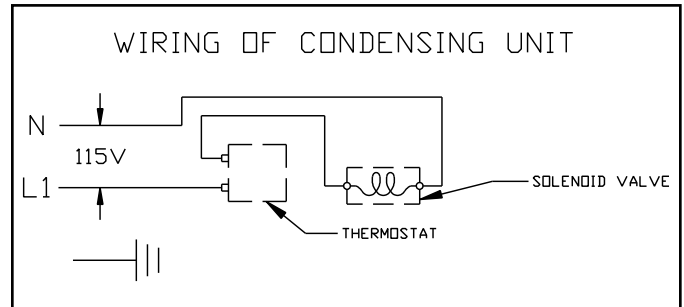

Figure 2

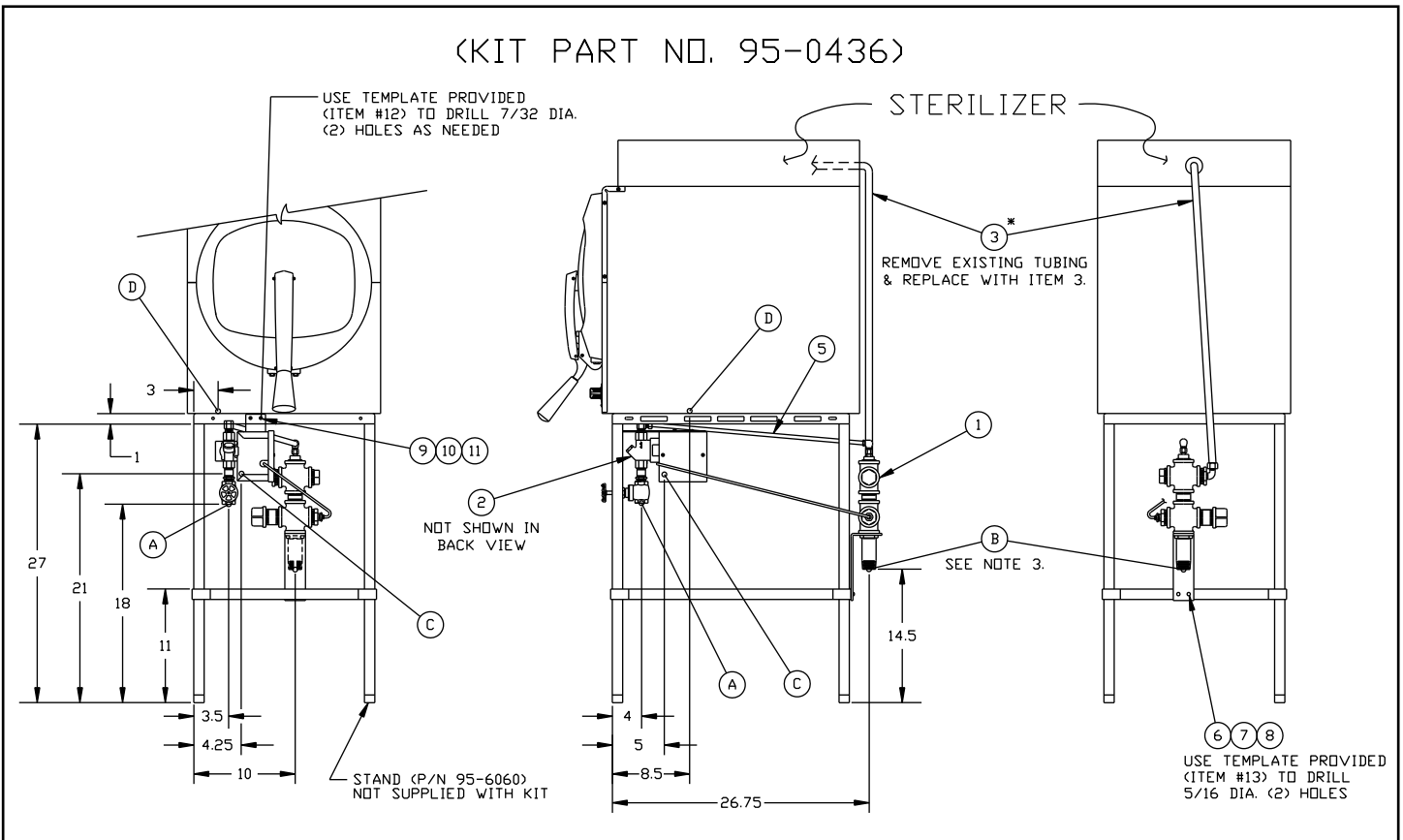

Figure 3

Pan Supports and Baffles

1. Locate the mounting studs on the inside of the chamber. There are two rack mounting studs on each side.

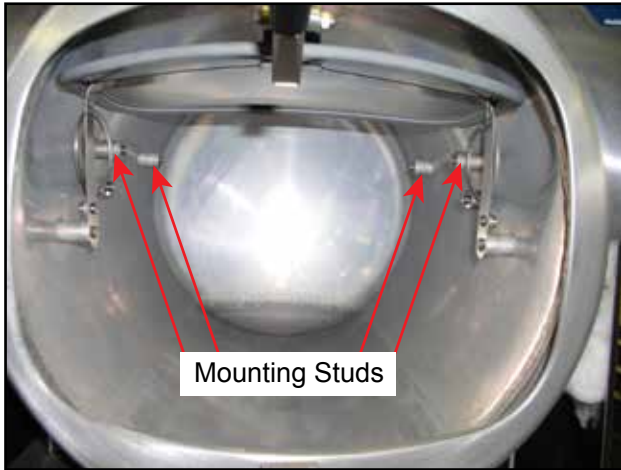

Figure 4

2. Taking one pan support and positioning rack so that the pan stop is facing the rear of the unit and the wires are facing toward the center of the unit. The pan stop is a piece of sheet metal welded to the rack with a 65° bend.
3. Begin to hang the pan support by placing the rear key-way slot onto the rear mounting stud and slide the rack until the slot sits on the mounting stud. When this is done correctly the front mounting stud will be in position to place the front key-way slot. Slide the rack down into its correct position.

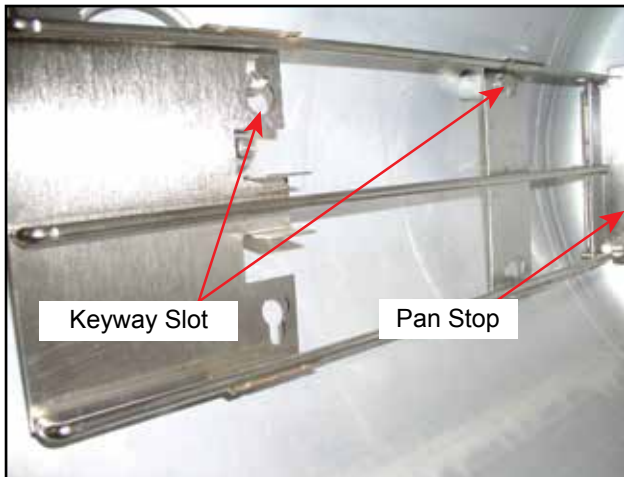

Figure 5

4. After installing one pan support rack correctly, you can install the upper baffle. Position the baffle so that the 45° bend is facing up towards the front of the unit (see "Figure 6"). Slide the mounting tab onto the flat bend on the pan stop bracket. The baffle should now stay in place by itself, but in a tilted state (see "Figure 7").

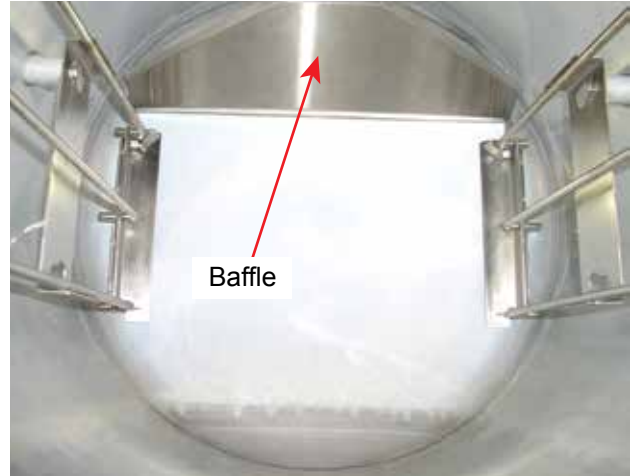

Figure 6



Figure 7

5. Position the second pan support rack into the cavity and slide the other mounting tab onto the rack flat bend while the pan support rack is not on the mounting studs. Hang the pan support by placing the rear key-way slot onto the rear mounting stud and slide the rack until the slot sits on the mounting stud. When this is done correctly the front mounting stud will be in position to place the front key-way slot. Slide the rack down into its correct position.
6. Place the Perforated Water Baffle so that it sits on the bottom of the inside of the sterilizer chamber.

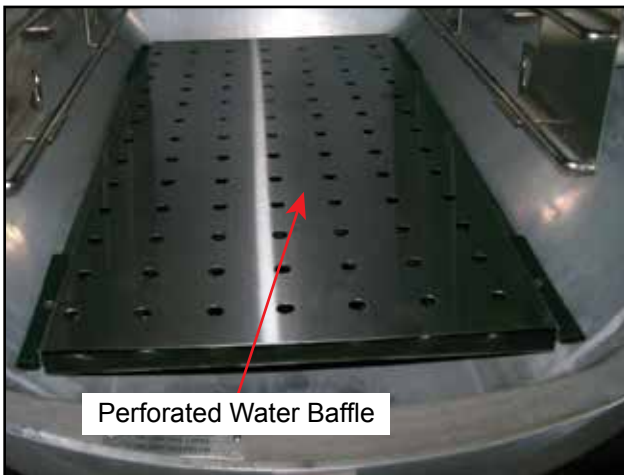

Figure 8

⚠ CAUTION

Do not cover the holes in the Perforated Water Baffle by using it as a shelf. This will result in a disrupted flow of steam.

Optional Stands

STERILMATIC OPEN STAND:

Market Forge Sterilmatic Stand can be supplemented with an Optional Stand for utility use where maximum compactness is desired.

The sturdy, stainless steel unit is equipped with adjustable leg extensions which allow the unit to be installed and leveled over existing contours in the floor.

The open design lends itself to maximum sanitary conditions because of the ease with which periodic cleaning can be done.

Though simple in design and appearance, the sterilmatic stand is the ideal arrangement for mounting in that it allows secondary air to circulate.

STERILMATIC OPEN STAND WITH CONDENSER

Market Forge can provide the open stand with an optional steam condenser system for use where steam exhaustion into the room is undesirable.

The condenser is automatically controlled by the thermostat. The normal factory thermostat setting is 130°F (54°C). The open under-shelf of the stand gives added utility providing a handy tabouret for utensils and access for drainage of water from the sterilizing chamber.

Part No.	50 Hz	Description
10-4653	10-4653	Thermostat
10-4035	10-7074	3/8" Solenoid
10-5731	10-5731	1/2" Water Stop Valve
95-2106	95-2106	Water Injection Assy.
95-1680	95-1680	Shelf

Optional Recording Thermometer

INSTALLATION FOR OPTIONAL RECORDING THERMOMETER

The optional recording thermometer may be surface or panel mounted whichever is preferred.

1. Remove the top cover of the sterilizer. Remove the pipe plug located in the T-fitting that also accommodates the safety relief valve and which is connected directly to the sterilizing chamber. (See figure to the right)
2. Insert the RTD temperature sensor of the temperature recorder through the rectangular cutout in the top cover then into the pipe from which the plug was removed.
3. Make sure RTD temperature sensor is protruding down into the sterilizer cavity but not too much so as to interfere with the sheet metal baffle plate. Tighten the compression fitting. Replace top cover onto the sterilizer.
4. For mounting the recorder on a wall, refer to the recorder manual supplied with the recorder.
5. Electrical connections: The 115/120VAC unit comes with a 6' power cord and three prong plug. This can be plugged into any 120V outlet. The 220/230VAC unit comes with a 6' power cord and three prong plug. However, due to the many varieties of plugs and outlets you may need to replace the plug with the appropriate plug.

The recording thermometer is a 24-hour clock and should be run continuously.

Charts should be changed every 24 hours.

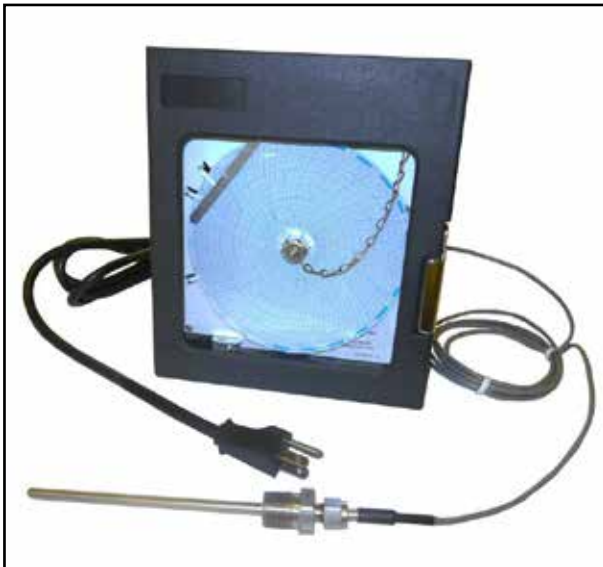

Figure 9

TO REMOVE THE CHART

1. Unscrew and remove the chart 'hub' knob (attached to the chain).

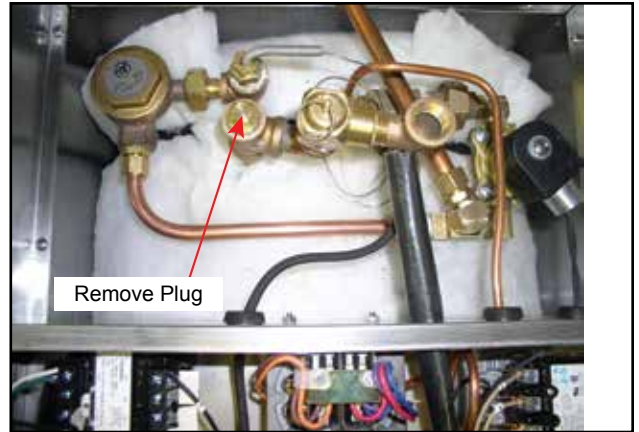

Figure 10

2. Grasp the edge of the chart and lift straight off.

TO INSTALL A NEW CHART

1. Slide edge of the chart under the two raised tabs located under the stylus.
2. Locate the center hole of the chart over the center, threaded rod. Rotate chart to line up the current time of day directly underneath the stylus print head.
3. Screw the chart 'hub' knob back in place, hand tight only.

Operating Instructions



IMPORTANT

Make sure the drain valve is closed. Fill bottom of the sterilizer chamber with approximately six quarts of water or just below ledge at bottom of door opening. (If water supply is known to be hard or corrosive, a source of treated water should be used.) DO NOT USE DISTILLED OR DEIONIZED WATER.

1. **LOAD STERILIZER:** Use proper sterilizer loading procedures when placing materials in sterilizer chamber. All solid containers or instruments must be placed so that water or air will not be trapped in them.
2. **CLOSE DOOR:** Grasp handle, and holding it in vertical position, pull door down until bottom of door rests in the bottom of door opening. Then rotate handle forward, engaging the lower curved portion under the horizontal rod in the casting at the bottom of the door opening. Push handle all the way down and back until door is locked securely in position.
3. **SET EXHAUST SELECTOR:** Located at center of the control housing mounted on top of the unit, to correct position. Unit is now ready to start. All items, other than solutions, may be sterilized with selector at "Instruments". Solutions require a low exhaust. Place selector at "Liquids".
4. **DETERMINE CORRECT STERILIZATION TIMES:** (Referring to next page for minimum required times in the sterilization guide and times table.)

NOTE: In no case should the timer be set to less than 15 minutes. Sterilization will not be accomplished in less than 15 minutes exposure time.
5. **TURN TIMER:** Located at upper right front of sterilizer. Select desired length of sterilizing period. This turns power supply on and starts the cycle after pressure-temperature combination has been reached. Amber pilot light indicates that the timer is running.
6. When the sterilizer chamber reaches the selected temperature, the timed exposure cycle will begin. When the exposure cycle is completed, the electric supply will be opened automatically. When the chamber pressure gauge located at the top of the control housing reads "0", the door may be opened. (Release handle and let go to avoid possible contact with remaining steam.) When opening the door, allow a few seconds for steam to escape from chamber before opening completely.

7. To assist in drying racks, release door handle after pressure has been attained at start of cycle. Pressure in chamber will keep door closed. The use of a wire basket will provide better drying for dressings. At end of sterilizing cycle, release door handle and open slightly. Do not lift door to open position. This will allow steam and moisture to escape. Allow door to remain in this position for 15 to 20 minutes before removing load. Small packs can be dried successfully with this procedure. We do not recommend the sterilization of large packs, such as linens. Be sure condensate baffles are in position in the chamber.
8. Remove load and check water level for next operation.

STERILIZATION GUIDE

- **PACKS (Linens, gloves, etc.):** Use wire basket to facilitate drying. Be sure condensate baffles are in place. Place packs on edge and arrange load in chamber, so that only minimal resistant to passage of steam through the load will exist. NOTE: Place gloves in upper two-thirds of chamber.
- **JARS, CANISTERS (etc.):** Place containers on side to allow for displacement of air and complete contact of steam to surfaces. Drying is also facilitated.
- **PETRI DISHES, PIPETTES, DESICCATORS (etc.):** Should be inverted.
- **UTENSILS, TREATMENT TRAYS:** Placed on edges to facilitate drying.
- **INSTRUMENT SETS:** Place instruments set in trays having mesh or perforated bottoms. Place trays flat on shelves.
- **COMBINING FABRICS & HARD GOODS:** Place hard goods on lowest shelves.
- **PLASTIC UTENSILS:** DO NOT stack or nest plastic items.
- **LIQUIDS:** Sterilize medium liquids separately from other supplies or materials. Set exhaust selector to proper position (liquids).
- **SMALL ITEMS:** Sterilize small items in baskets, or trays.

Minimum Sterilization Times

TIME (Minutes)	ARTICLES
15	<ul style="list-style-type: none">• Glassware, empty, inverted.• Instruments, metal in covered or open tray, padded or unpadded.• Needles, unwrapped.• Pipettes, blood diluting, serological, volumetric, etc• Tubing glass (6mm), (10mm) inverted
20	<ul style="list-style-type: none">• Flasked solutions 75-250 ml.• Instruments, metal combined with other materials in covered and/or padded tray.• Instruments wrapped in double thickness muslin.• Rubber gloves, catheters, drains, tubing, etc. Unwrapped or wrapped in muslin or paper.
30	<ul style="list-style-type: none">• Brushes in dispensers, in cans or individually wrapped.• Dressings, wrapped in paper or muslin, small packs only.• Flasked solutions 500-1000 ml.• Syringes, unassembled, individually packaged in muslin or paper.• Needles, luer, individually packaged in glass tubes or paper.
45	<ul style="list-style-type: none">• Flasked solutions 1500-2000 ml.

Cleaning

DAILY CLEANING PROCEDURE (AT THE END OF EACH DAY):

When sterilizing culture mediums that generate sulfide gas or chlorine gas, the inside of the chamber must be cleaned and rinsed thoroughly without fail.

1. Remove bottom splash baffle.



IMPORTANT

STERILIZING CHAMBER MUST BE CLEANED AND DRAINED DAILY USING THE FOLLOWING PROCEDURE. WASH WETTED PORTION OF THE CYLINDER THOROUGHLY BY ADDING A MILD DETERGENT TO WATER IN CYLINDER.

2. If a soft cloth or brush is used with the detergent and does not completely remove the surface film, a nylon soap pad should be used. After washing thoroughly rinse with clean water. Dry cylinder* and leave door open overnight.

* The Sterilmatic cylinder is constructed of corrosion resistant Alclad aluminum alloy. The protective properties of this material afforded to the interior portion of the cylinder which is exposed to water may be destroyed by allowing a film to form. Such a film can be caused by salts or other contaminants in the water. Corrosion may also occur if water is not drained daily.

STERILIZER (AUTOCLAVE) WARRANTY

MODELS: STM-E, STM-EL, STM-EX* AND STM-ELX*

We warrant to the original purchaser that the sterilizers manufactured by Market Forge Industries, Inc. will be free from defects in material and factory workmanship if properly installed and operated under normal conditions. Within one year from date of original installation, or within 15 months from date of shipment from factory, whichever is sooner, we will repair or replace that part of any such machine that becomes defective at no cost to the customer.

This warranty is effective for One (1) Year Parts and 90 Days Labor, Travel and Mileage.

This warranty does not apply to damage resulting from use of hard or corrosive water, from failure to drain and dry cylinder daily or from inadequate cleaning procedures. Nor does it cover any part or assembly, which has been subjected to accident, alteration, or is from a machine where the serial number has been removed or altered. Normal service adjustments are not covered by this warranty.

Any defect during the warranty period shall be brought to the attention of a factory authorized service agency or the dealer from whom the equipment was purchased. He will be authorized to furnish or arrange for repairs or replacements within the terms of the warranty.

NOTE: This warranty only applies to the USA and Canada. Elsewhere, warranty covers parts only for one year as described above.

** Export Model.*



MARKET FORGE INDUSTRIES
44 Lakeside Avenue
Burlington, Vermont 05401 USA
Telephone: (802) 658-6600
Fax: (802) 864-0183

www.mfi.com